

## DETAILED WRITTEN INSTALLATION INSTRUCTIONS

In floor requirements – 2 x ½” BSP male threads at 150mm centres.

Distance from wall to centre of threads is approximately 53mm.

1. Mount both floor flanges onto male threads, making sure appropriate thread sealant is used.
2. Mount pillar clips at an appropriate distance above and in line with male threads. Mount risers onto floor flanges.
3. Place breech assembly onto risers and tighten nut with spanner making sure thread sealant is used.
4. Tighten compression nuts onto floor flanges with a spanner.
5. Tighten pillar clips with flat headed screwdriver. TAKE CARE – as the riser tube can be easily scratched by pillar clip.
6. Fit arm on the riser and tighten with thread tape/sealant.
7. Place arm and riser assembly onto breech outlet and tighten compression nut with spanner.
8. Tighten pillar clip with flat headed screwdriver, taking care of riser tube to prevent damage.
9. Attach rose with thread tape/sealant.

**IMPORTANT** Maximum hot water temperature 65° C and 500 kPa Maximum operating pressure at any outlet within a building (Ref AS/NZS 3500)

**WARRANTY** The Company accepts responsibility for any fault due to the Company's own workmanship or materials except for subjective variations or random unavoidable blemishes of a minor non-functional nature. This acceptance of responsibility is for 5 years from the date of installation, proof of which may be required.

Last Review Date: 10/08/2020



CB IDEAL TAPWARE PTY LTD

1A DELORAINIE ROAD, EDWARDSTOWN S.A. 5039

PH: (08) 8276 6766 | sales@cbideal.com.au

ABN: 98 156 625035 | ACN: 156 625 035

# ALCOVE SHOWER SET WITH FLOOR LEGS

## INSTALLATION INSTRUCTIONS

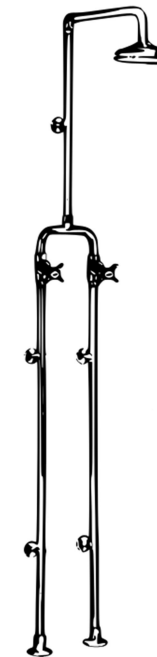

[www.cbideal.com.au](http://www.cbideal.com.au) | [sales@cbideal.com.au](mailto:sales@cbideal.com.au)

1

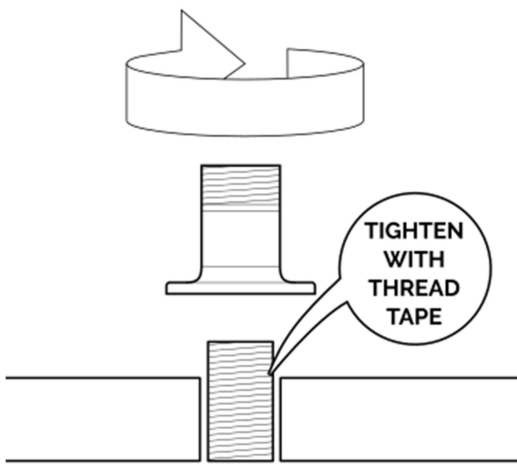

X2

2

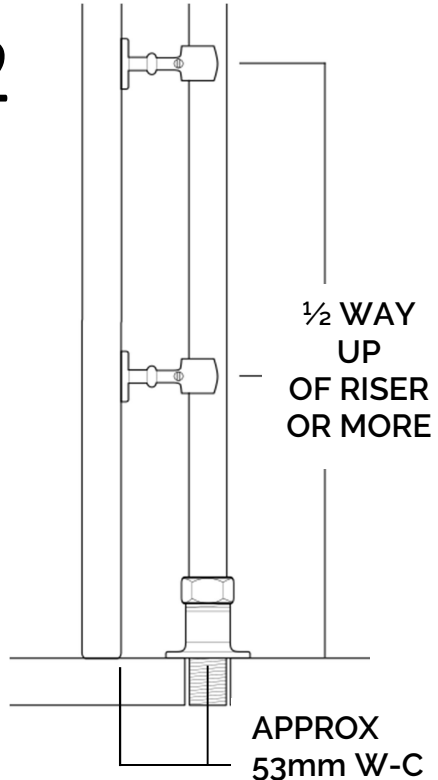

3

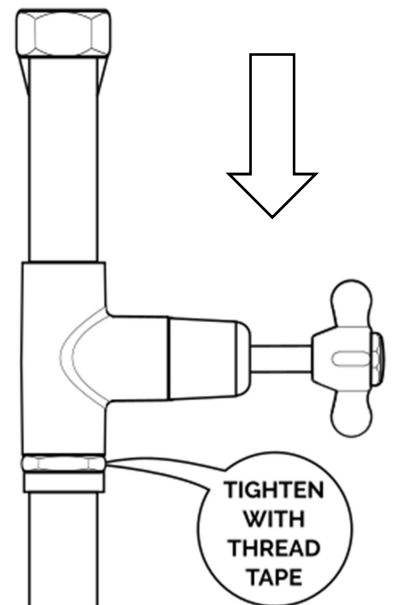

X2

4

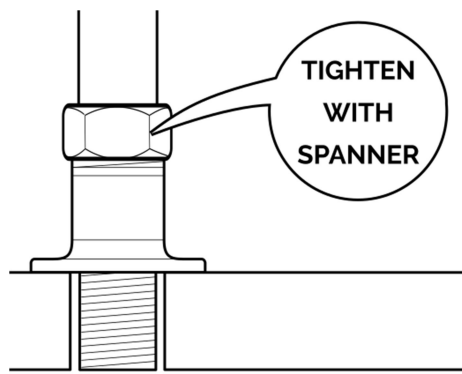

X2

5

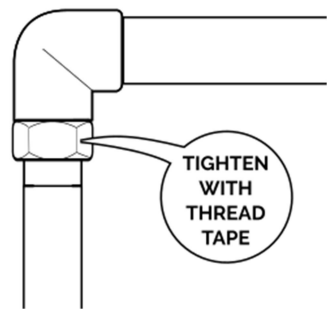

6

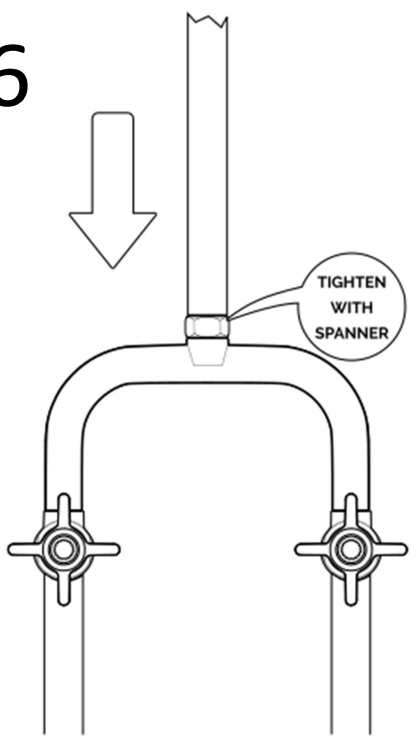

7

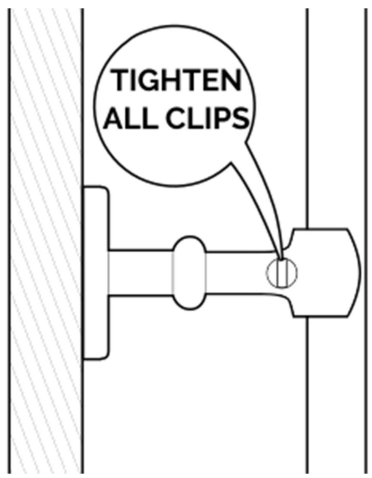

8

