

## DETAILED WRITTEN INSTALLATION INSTRUCTIONS

In wall requirements – 2 x ½” BSP male threads at 150mm centres

1. Take angle taps from set as supplied, install pressed flanges and taps on to in-wall threads (use thread tape) with outlets of taps pointing upwards.
2. Fit nuts and olives on to breaching piece.
3. Tighten nuts down on to outlets of taps in above with a spanner.
4. Install pillarclip on wall at a suitable point vertically above centre thread on breaching piece connection, to hold shower riser tube (Half the length of the riser tube above breaching piece or higher).
5. Fit shower riser (with nut and olive) to centre thread on breaching piece and tighten with a spanner. The shower riser tubing can be cut to the desired height.
6. Fit shower riser tube in to pillarclip and tighten with a flat-head screwdriver. TAKE CARE – as the riser tube can be easily scratched by pillarclip.
7. Attach rose ball joint assembly to the riser with a spanner and tighten. Use thread tape. Grease ball joint as required.
8. Put o-ring on rose as per diagram and attach rose to ball joint assembly. Tighten by hand. TAKE CARE – not to overtighten.

**IMPORTANT** Maximum hot water temperature 65° C and 500 kPa Maximum operating pressure at any outlet within a building (Ref AS/NZS 3500)

**WARRANTY** The Company accepts responsibility for any fault due to the Company's own workmanship or materials except for subjective variations or random unavoidable blemishes of a minor non-functional nature. This acceptance of responsibility is for 5 years from the date of installation, proof of which may be required.



CB IDEAL TAPWARE PTY LTD

1A DELORAINIE ROAD, EDWARDSTOWN S.A. 5039

PH: (08) 8276 6766 | sales@cbideal.com.au

ABN: 98 156 625035 | ACN: 156 625 035

# ALCOVE SHOWER SET WITH GOOSENECK RISER

## INSTALLATION INSTRUCTIONS

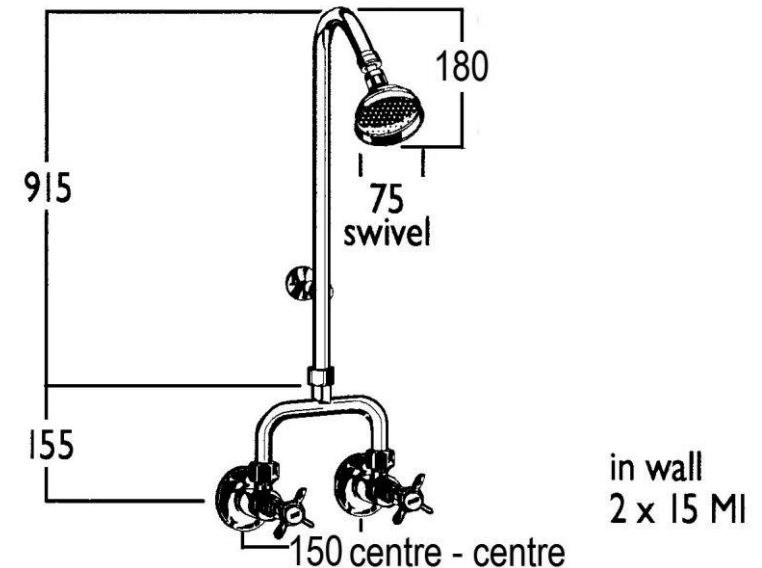

[www.cbideal.com.au](http://www.cbideal.com.au) | [sales@cbideal.com.au](mailto:sales@cbideal.com.au)

1

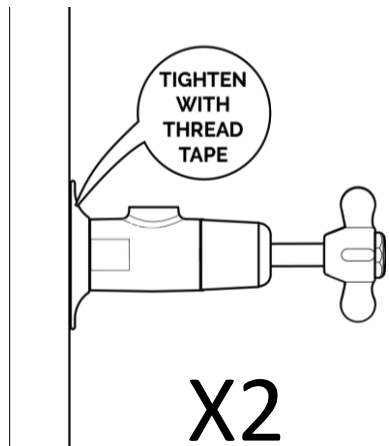

2

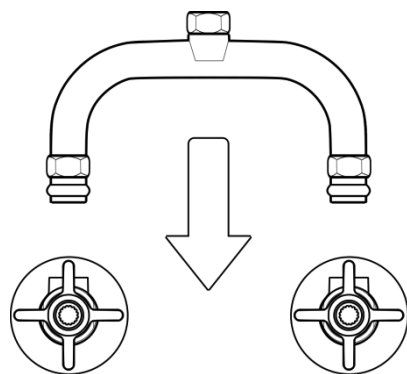

3

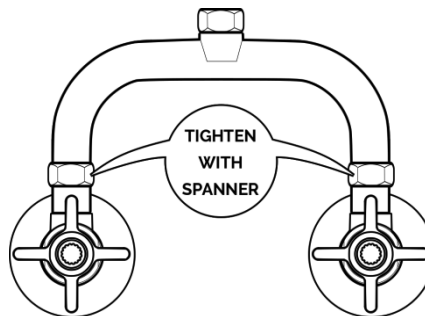

4

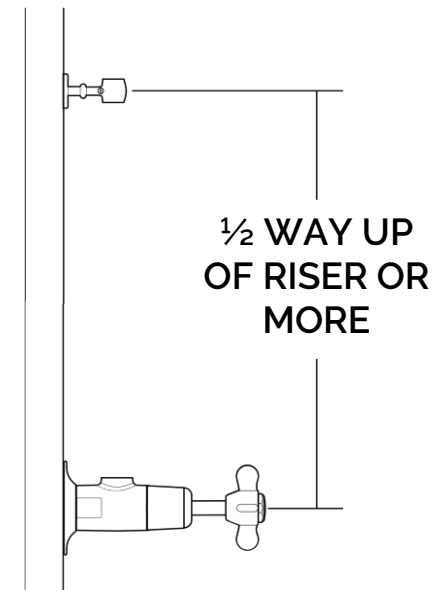

5

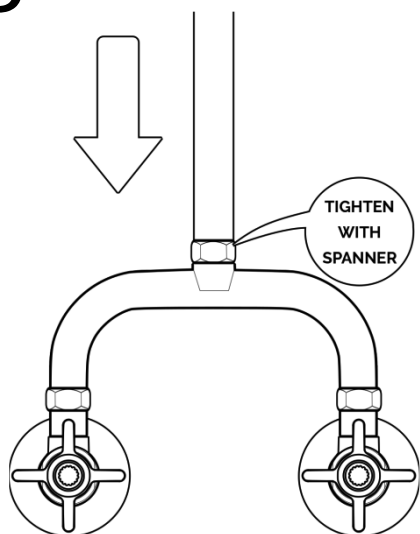

6

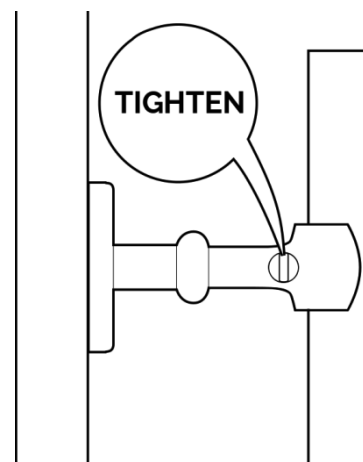

7

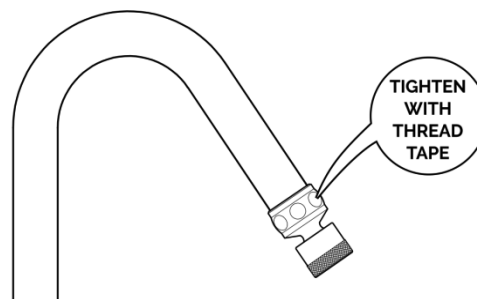

8

